



PT INDOMOBIL SUKSES INTERNASIONAL Tbk

WISMA INDOMOBIL 6th Floor, Jl. MT. Haryono Kav. 8, Jakarta 13330
Phone: 62-21 8564850, 8564860, 8564870 (hunting)
Facsimile: 62-21 8564833
Web site: <http://www.indomobil.com>

No. 521/IMSI/CS-332/VII/2014

2 Juli 2014

Kepada Yth.
Kepala Pengawasan Pasar Modal
Otoritas Jasa Keuangan
Gedung Soemitro Djohadikusumo Lantai 1
Jl. Lapangan Banteng Timur No.2-4
Jakarta 10710

Perihal : Laporan dan Keterbukaan Informasi Pelaksanaan Transaksi Afiliasi

Dengan hormat,

PT CENTRAL SOLE AGENCY ("CSA"), salah satu anak perusahaan yang 99,99% sahamnya secara langsung dan tidak langsung dimiliki oleh PT INDOMOBIL SUKSES INTERNASIONAL Tbk ("Perseroan") telah melaksanakan transaksi penerimaan fasilitas perbankan dari PT BANK CENTRAL ASIA Tbk ("BCA"), sedangkan Perseroan telah menjaminkan sebidang tanah Sertifikat HGB No. 68/Manis Jaya milik Perseroan kepada BCA untuk menjamin pelunasan pembayaran hutang CSA kepada BCA terkait dengan fasilitas perbankan tersebut ("Penjaminan Tanah Milik Perseroan kepada BCA").

Sehubungan dengan hal tersebut di atas, dalam rangka memenuhi ketentuan angka 2 Paragraf (b) butir 5 dari Peraturan No.IX.E.1, lampiran Keputusan Ketua Bapepam dan LK No. KEP-412/BL/2009 tanggal 25 November 2009 tentang Transaksi Afiliasi Dan Benturan Kepentingan Transaksi Tertentu ("Peraturan No.IX.E.1"), dengan ini kami sampaikan laporan yang memuat penjelasan terperinci perihal transaksi tersebut yaitu sebagai berikut:

1. Uraian Transaksi

- a. Berdasarkan Perubahan Perjanjian Kredit tertanggal 30 Juni 2014 yang dibuat dibawah tangan jo. Akta Perjanjian Kredit tertanggal 19 September 2008 No. 80, dibuat dibuat di hadapan Mellyani Noor Shandra SH, Notaris di Jakarta, berikut segenap perpanjangan, perubahan dan/atau penambahannya dari waktu ke waktu, antara lain telah disepakati bahwa CSA memperoleh fasilitas kredit dari BCA.
- b. Atas penerimaan fasilitas kredit tersebut, Perseroan telah memberikan jaminan untuk terlaksananya pembayaran hutang CSA kepada BCA tersebut dalam bentuk harta kekayaan milik Perseroan yang berupa sebidang tanah Sertifikat HGB No. 68/Manis Jaya, sebagaimana diuraikan dalam Surat Ukur tertanggal 2 Desember 1997 No. 10.25.04.15.00002/1997, seluas 57.350 m² (lima puluh tujuh ribu tiga ratus lima puluh meter persegi), terletak di dalam Propinsi Banten, Kotamadya Tangerang, Kecamatan Jatiuwung, Kelurahan Manis Jaya, setempat dikenal sebagai Jalan Raya Gatot Subroto Km 8,5.
- c. Pemberian jaminan sebagaimana tersebut di atas dilakukan melalui penandatanganan Akta Pemberian Hak Tanggungan pada tanggal 30 Juni 2014, dengan memakai ketentuan-ketentuan dan syarat-syarat yang dianggap baik oleh Direksi Perseroan.

[Handwritten signature]



- d. CSA adalah pihak yang terafiliasi dengan Perseroan dengan sifat hubungan afiliasi sebagaimana dapat dilihat dalam bagan hubungan kepemilikan saham dan tabel susunan kepengurusan sebagaimana berikut ini:

Bagan Kepemilikan Saham

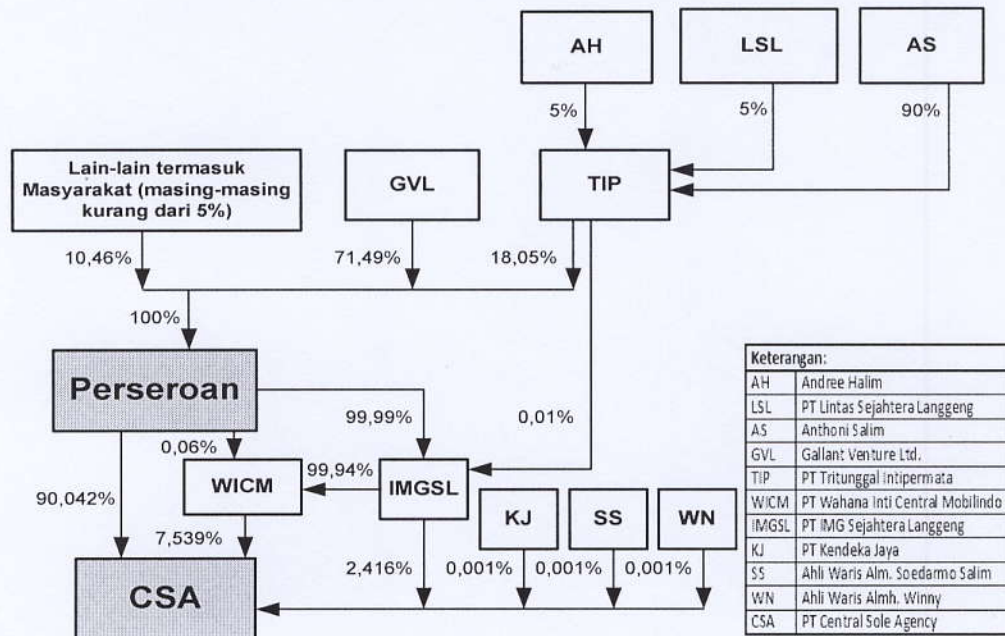

Tabel Susunan Kepengurusan

NAMA	Perseroan	CSA
Jusak Kertowidjojo	Direktur Utama	Direktur Utama
Jacobus Irawan	Wakil Direktur Utama	---
Josef Utamin	Direktur	Direktur
Alex Sutisna	Direktur	Komisaris Utama
Santiago Soriano Navarro	Direktur	---
Bambang Subijanto	Direktur	Wakil Direktur Utama
Evensius Go	Direktur	---
Soebronto Laras	Komisaris Utama	---
Pranata Hajadi	Wakil Komisaris Utama	---
Dr.-Ing. Gunadi Sindhuwinata	Komisaris	---
Eugene Cho Park	Komisaris	---
Soegeng Sarjadi	Komisaris Independen	---
Drs Hanadi Rahardja	Komisaris Independen	---
Mohamad Jusuf Hamka	Komisaris Independen	---
Andreas Dhanu Sugih	---	Direktur
Willianto Husada	---	Komisaris

2. Penjelasan, pertimbangan dan alasan dilaksanakannya transaksi

Penjaminan Tanah Milik Perseroan kepada BCA dimaksudkan untuk menjamin pelunasan fasilitas perbankan yang diterima CSA ("Pinjaman CSA"). Pinjaman CSA ini adalah untuk menunjang kegiatan usaha Entitas Anak tersebut, sehingga diharapkan hasil usahanya akan memberikan dampak positif terhadap Laporan Keuangan CSA yang secara tidak langsung juga akan memberikan dampak positif terhadap Laporan Keuangan Konsolidasian Perseroan secara keseluruhan, dan pada akhirnya memberikan keuntungan bagi pemegang saham publik Perseroan.

3. Pernyataan Dewan Komisaris dan Direksi

Berdasarkan Surat Pernyataan tertanggal 2 Juli 2014 yang ditandatangani oleh seluruh anggota Direksi dan Dewan Komisaris Perseroan, para Direksi dan Komisaris menyatakan bahwa semua informasi material terkait dengan Penjaminan Tanah Milik Perseroan kepada BCA yang intinya sebagaimana tertera dalam surat ini, adalah telah diungkapkan secara lengkap dan tidak menyesatkan.

Demikian informasi yang dapat kami sampaikan terkait dengan pelaksanaan Penjaminan Tanah oleh Perseroan kepada BCA.

Hormat kami,

PT Indomobil Sukses Internasional Tbk



Jacobus Irawan
Wakil Direktur Utama

Santiago Soriano Navarro
Direktur

Tembusan:

- Yth. Direksi PT Bursa Efek Indonesia

July 2, 2014

No. 521/IMSI/CS-332/VII/14

To:
Head of Capital Market Supervisory
Indonesia Financial Services Authority
Gedung Sumitro Djojohadikusumo
Jl. Lapangan Banteng Timur No. 2-4
Jakarta 10710

Subject : The Report and Disclosure of an Affiliated Transaction

Dear Sir,

PT CENTRAL SOLE AGENCY (“CSA”), which 99.99% of its shares are owned direct and indirectly by PT INDOMOBIL SUKSES INTERNASIONAL Tbk (“Company”), has conducted transaction concerning the obtaining of banking facility from PT BANK CENTRAL ASIA Tbk (“BCA”), while the Company has encumbrance a plot of land with Right to Build Certificate No. 68/Manis Jaya owned by the Company to BCA to secure the repayment of CSA’s debt to BCA related to such banking facility (“The Encumbrance of Security Rights Over the Company’s Land to BCA”).

In connection with the above, in order to comply with the provision number 2 Paragraph (b) point 5 of the Regulation No.IX.E.1, Attachment of Decision of the Chairman of Bapepam and LK No. KEP-412/BL/2009 dated 25 November 2009 regarding the Transaction with Affiliated Parties and Conflict of Interest on Certain Transaction (“Rule No. IX.E.1”), we hereby submit a report containing a detailed explanation regarding such transaction as follows:

1. Description of Transaction

- a. Based on the Amendment of Credit Agreement dated 30 June 2014, privately drawn up and the Deed of Credit Agreement dated 19 September 2008 No.80, made before Mellyani Noor Shandra SH, Notary in Jakarta, including all renewal, amendment and/or additional from time to time, among others has agreed that CSA obtained credit facility from BCA.
- b. For the acceptance of such credit facility, the Company has provided a guarantee to secure the repayment of CSA’s debt to BCA, in the form of the Company’s property, namely a plot of land with Right to Build Certificate No. 68/Manis Jaya, as stipulated in the Measurement Letter dated 2 December 1997 No. 10.25.04.15.00002/1997, covering an area of 57,350 m² (fifty-seven thousand three hundred and fifty square meters), located in Banten Province, Tangerang Municipality, Jatiuwung District, Manis Jaya Sub-district, locally known as Jalan Raya Gatot Subroto Km 8.5. (“The Company’s Land Mortgage”)
- c. The Company’s Land Mortgage was made by way of Deed of land mortgage dated 30 June 2014, with terms and conditions which were deemed proper by the Board of Directors of the Company.

d. CSA is affiliated with the Company as per below shareholder structure:

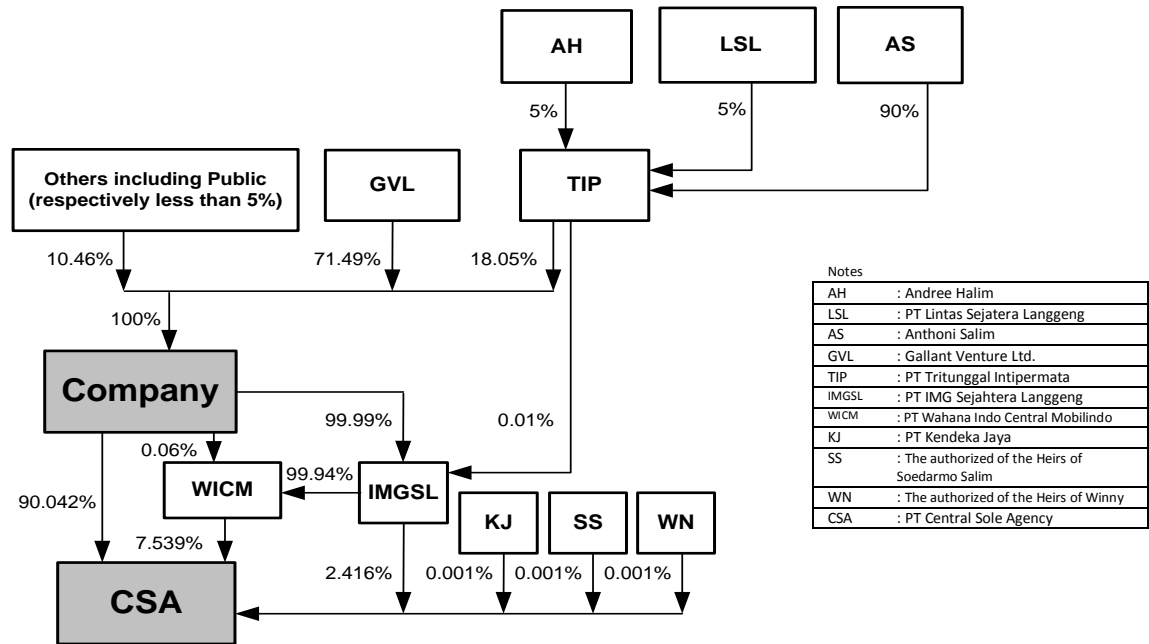

Table of the Composition of Management

Name	Company	CSA
Jusak Kertowidjojo	President Director	President Director
Jacobus Irawan	Vice President Director	---
Josef Utamin	Director	Director
Alex Sutisna	Director	President Commissioner
Santiago Soriano Navarro	Director	---
Bambang Subijanto	Director	Vice President Director
Evensius Go	Director	---
Soebronto Laras	President Commissioner	---
Pranata Hajadi	Vice President Commissioner	---
Dr.-Ing.Gunadi Sindhuwinata	Commissioner	---
Eugene Cho Park	Commissioner	---
Soegeng Sarjadi	Independent Commissioner	---
Drs Hanadi Rahardja	Independent Commissioner	---
Mohamad Jusuf Hamka	Independent Commissioner	---
Andreas Dhanu Sugih	---	Director
Willianto Husada	---	Commissioner

2. Explanation, Consideration and Reason of Transaction

The Company's Land Mortgage is intended to secure the repayment of banking facility received by CSA ("CSA Loan"). This CSA Loan intended to support the operating activities of such Subsidiary Company, therefore, it is expected that its operation result may give a positive impact to the Financial Report of CSA which indirectly will give a positive impact to the Consolidated Financial Report of the Company and to contribute profit to the public shareholders of the Company.

3. Statement of the Board of Commissioners and the Board of Directors

By the Statement Letter dated July 2, 2014, signed by all members of the Board of Directors and the Board of Commissioners of the Company, the Board of Directors and the Board of Commissioners certify that all of the material information relating to the Encumbrance of Security Over the Company's land to BCA which mainly as stated in this letter, has been completely disclosed and not misleading.

With the above, we submit the information regarding The Company's Land Mortgage.

Regards,

PT Indomobil Sukses Internasional Tbk

Jacobus Irawan

Vice President Director

Santiago Soriano Navarro.

Director

cc:

The Board of Directors of Indonesia Stock Exchange